

Trucks for life
ISUZU

C & E-SERIES

Heavy-Duty Truck and Tractor Unit





Eye-catching style plus fuel-efficient aerodynamics

Not does cab styling make a bold statement, aerodynamic and cooling performance is taken to the next level in the C&E Series. The open area of the front grille allows more air to reach the radiator and boosts performance of the intercooled turbocharger, raising fuel efficiency.

Plenty of cabin space and better handling

Drivers will appreciate two more benefits of the aerodynamic styling: plenty of interior space and improved handling. There's ample room to spread out and relax during long hauls, while cutting wind resistance results in effortless handling.





Simplified rear-body mounting and trailer versatility

The wide wheelbase and rugged construction of the C&E Series undercarriage simplifies mounting of rear bodies and trailers for specific applications. Engineered to be lightweight and durable, the chassis realizes cost-effective handling of heavy loads and is one reason ISUZU is establishing a worldwide reputation as a global brand in the heavy-duty segment.



The sub-name plate shows technologically maximum GVM (first two digits) and engine output (last two digits) at a glance.

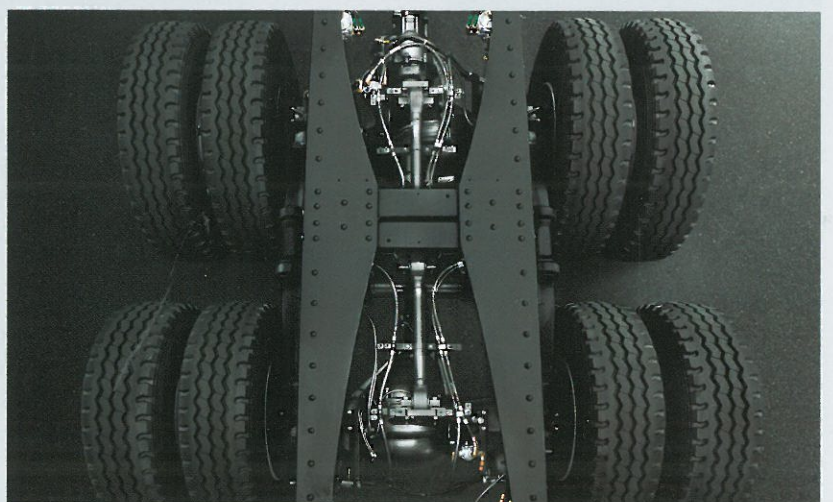

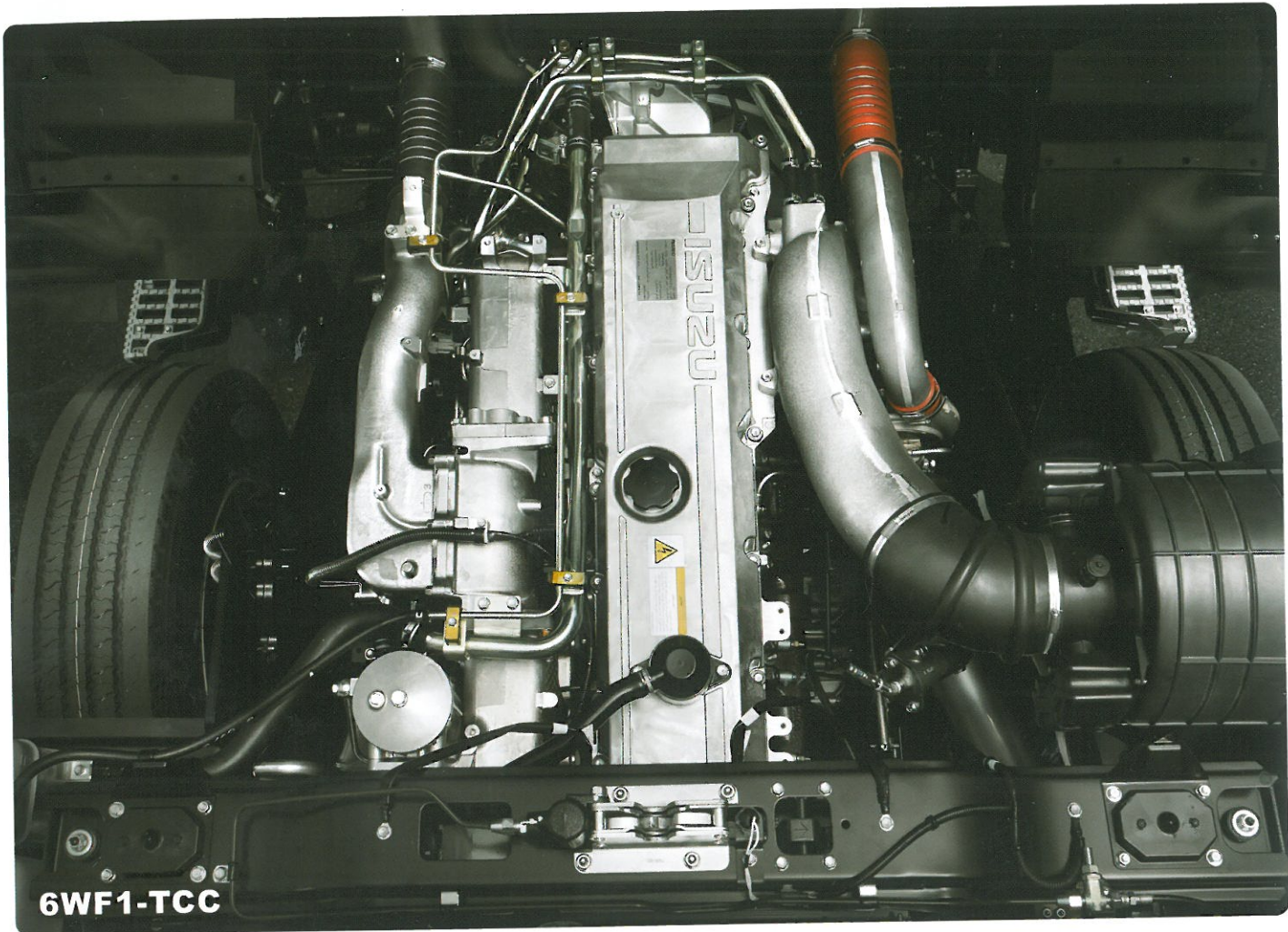

6WF1-TCC

Easy on the environment and your pocketbook

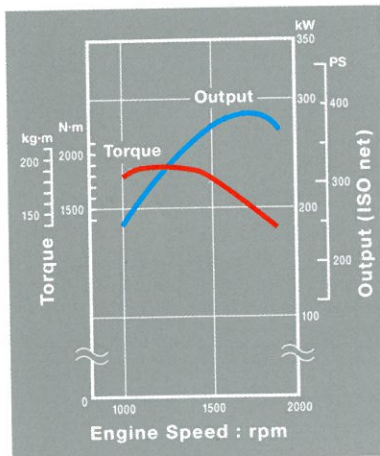

The 6WF1-TCC diesel packs a number of advanced technologies into a compact format that produces a hefty 390PS while reducing emissions and raising fuel economy.

Low-speed torque and acceleration are also improved, making this engine ideal for use in a wide range of applications.

6WF1-TCC Direct-Injection OHC

- Displacement 14,256 cc
- Max. Output 287kW(390PS)/1,800rpm
- Max. Torque 1,863N·m(190kg·m)/1,100rpm

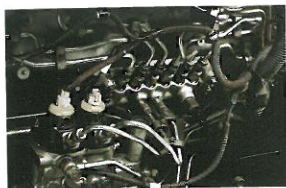

Precise electronic control of common rail system

Reduced emissions and better fuel economy are the benefits of super high-pressure fuel injection, which incorporates precise electronic control for greater engine efficiency.



Turbocharger maximizes low-speed performance

The intercooled turbocharger system maximizes low-speed torque and acceleration. The 6WF1-TCC diesel is perfect for heavy hauling and high-volume distribution.



7-speed and 16-speed transmissions are available.

Thanks to its wide gear range, the 16-speed transmission provides precise gear selection and better fuel economy during every driving conditions. This transmission is a big reason for the C&E Series' reputation for reliability.

Inhibitor shift warning alerts drivers (16-speed transmissions only)

The Inhibitor warning is a convenient feature that warns drivers when shifting into the wrong gear. By helping to ensure correct shifting, driver control and fuel economy are enhanced.

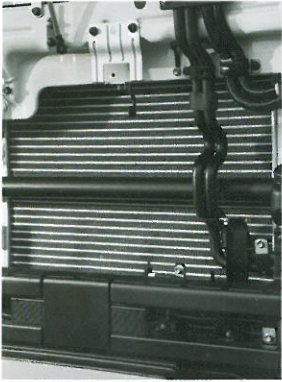

Aerodynamic cab design lowers fuel costs

Corner vanes, blister fender, air-dam bumper – every facet of the cab is designed to cut wind resistance and raise cooling efficiency. Operators will see the benefits in lower fuel costs.



High-clearance pipe and vertical silencer

The rear pipe and vertical silencer are carefully positioned to clear rear bodies and provide optimum height from ground for better running performance.



Taper-leaf suspension

Heavy-duty suspension for big loads

Designed specifically for high carrying capacity, the C&E Series features extra-strength front and rear leaf-spring suspension to absorb vibration, protect cargo and provide a smooth ride. There is two-types of suspension available. For enhanced operation on uneven terrain, the highly rigid frame resists torsion forces and increases overall durability.

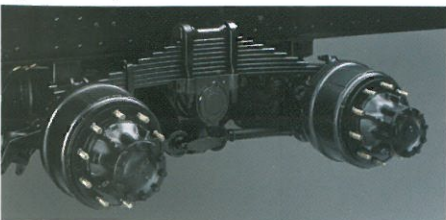

Multi-leaf suspension (option)

Variety of tires sizes to match the job

From standard 295/80R and optional 315/80R tubeless tires to 11.00R 20 tube tires, there is a tire size to match your exact application. Off-road RIBLUG tires or on-road RIB tires can be selected.



Winning combination of safety and service

In addition to highly rigid cab construction and steel door beams to protect occupants, a carefully thought-out mirror system provides an expanded safety zone to protect pedestrians and other vehicles when turning and changing lanes. Easy maintenance is another strongpoint of the C&E Series. Fluids and filters are readily accessed through the front panel, while the power tilt-cab mechanism simplifies engine and transmission service.

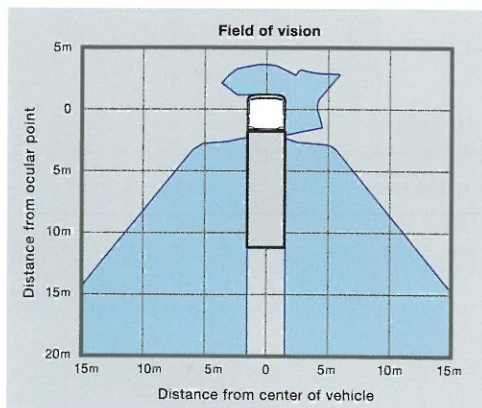

Better mirror visibility for safer driving

Wide-angle mirrors on the driver's side and co-driver's side as well as front and side undermirrors on the co-driver's side expand visibility, helping to prevent "underrun" and contact accidents during turns or merging.



Wide illumination area and full-coverage wipers

Nighttime safety gets a boost from larger headlamp bulbs, which increase the illumination area; at dawn or twilight, use of clearance lamps makes the vehicle more visible. Full-coverage wipers keep the windshield clear even in extreme conditions.

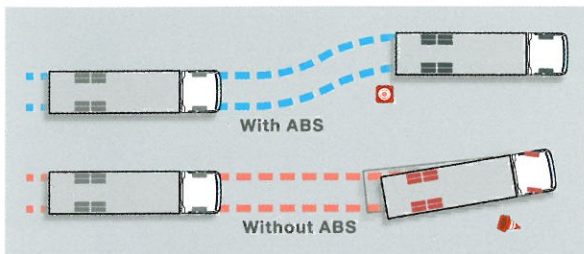

ABS eliminates wheel lockup

The complete control of an Antilock Braking System is standard on every C&E model. During emergencies or hard braking on slippery surfaces, ABS keeps wheels from locking up and allows the driver to maintain control of the vehicle. Extra-large front and rear drum brakes improve ABS performance.



Wheel parking and trailer brake

Both the parking brake and trailer brake are located at the driver's side for better brake control.



Worry-free trailer coupling

Full and secure coupling of tractor and trailer is essential for peace of mind and safety. (CZ51Q full trailer)

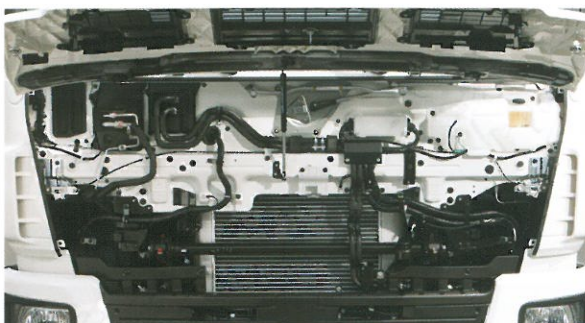

Quick-access panel for easy inspection

Daily inspection of fluid reservoirs, filters and other components takes no time at all, due to the front access panel. By encouraging daily inspection, the access panel prevents minor issues such as low fluids from turning into major repairs.



Protective insect screen

An insect screen over the radiator grille protects vehicles from damage caused by insects and stone chips.



Replaceable sedimenter filters

Both sedimenters feature replaceable filters – there is no need to replace the entire cartridge. Besides the cost benefit, filters are highly effective and easily remove deposits and water from oil.



Locking fuel tank with step

A locking fuel-tank cap prevents theft and spillage. On E-Series tractors, a convenient step for platform access is built into the 550-liter fuel tank.



Pre-air cleaner for long filter life

A pre-air cleaner extends the service life of the air cleaner element and is particularly well suited to a variety of uses especially in sandy and dusty areas.



More comfort means effortless operability

Cab comfort and easy operation go hand in hand. ISUZU looked carefully at what drivers need to make their job easier. High on the list are quick-read meters, storage and various convenience features, such as an optional bed for a quick nap or good rest after a hard day.

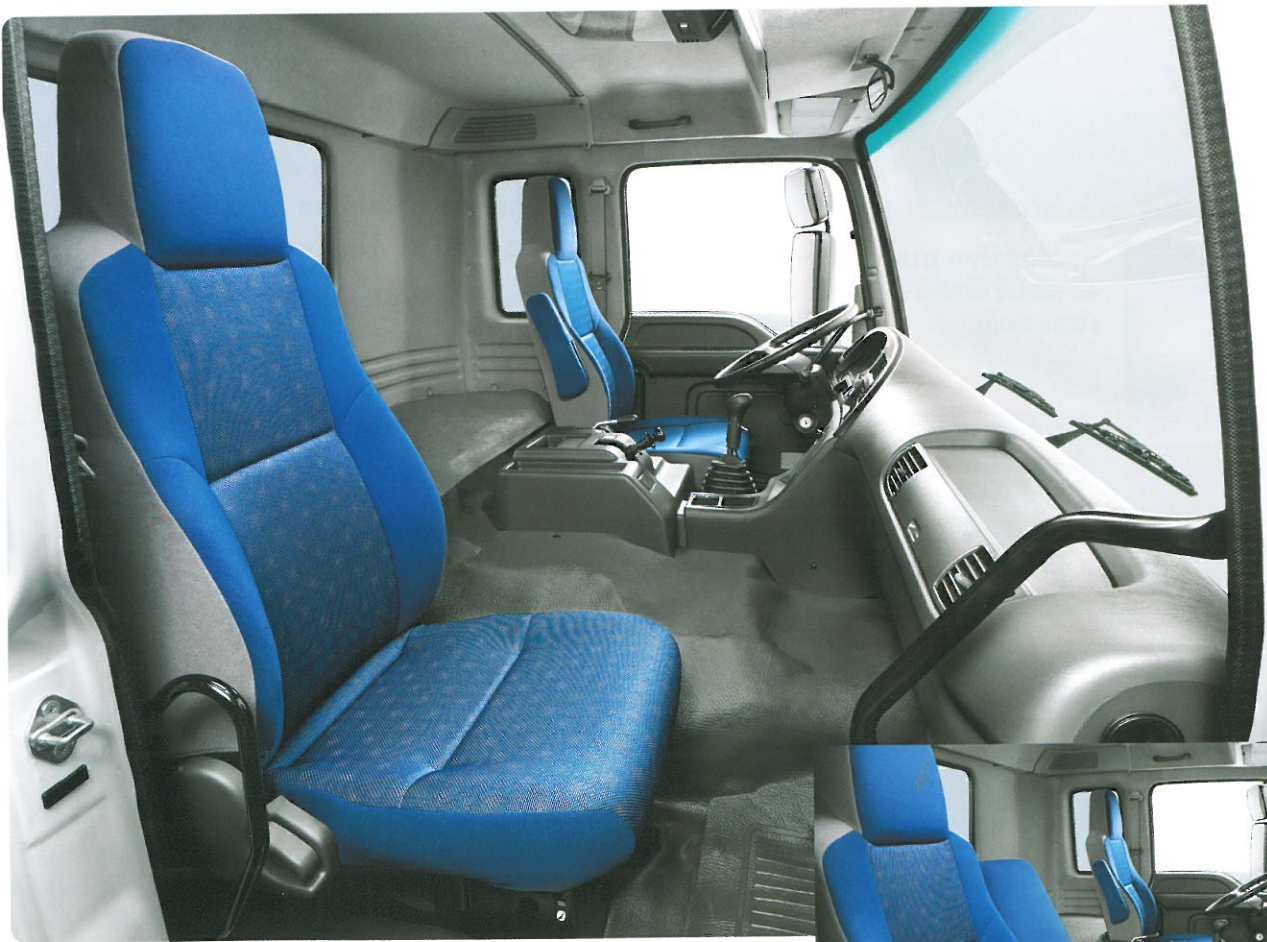

Bed, Center seat (option)



High-visibility meters

Allow confirmation of vehicle status at a glance



Covered overhead shelf

Ideal for communications equipment or long items



Fluorescent lamp

Brightens every corner of the cab

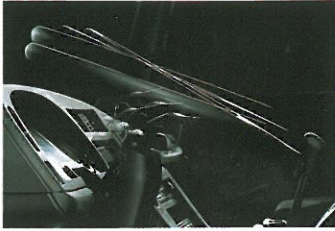

Tilt and telescopic steering

Creates the ideal driving position



Power steering

Helps to reduce driver fatigue



Power window switch/lock

Convenience and safety at your fingertips



Center seat back tray

Back of seat becomes a tray when folded down



Cup holders

Keep two cups or cans within easy reach of driver



Air conditioner

Cab atmosphere stays fresh and clean



Windshield shade band

Blocks glare and improves visibility



UV-cut door glass

Cuts UV rays for a more comfortable driving environment



Room mirror

Allows driver to check rear of cabin and through rear window



AM/FM radio with CD player

Produce superior sound quality



Spacious bed

Optional bed to relax after a long day of driving



Round curtain

Handy option to assure privacy and keep rear cabin clutter out of view



Actual curtain fabric



Reclining seat

Driver's seat fully reclines for a quick nap



Air suspension seat

Cushions are pneumatically maintained at perfect level; high headrest improves safety (standard on EXR/EXZ models)

*High headrest is for LHD model only.

Easy cab access

Three steps and handgrips facilitate cab ingress/egress



6x4 HEAVY-DUTY FORWARD CONTROL TRUCK

CYZ

GVM 33,000kg



Vertical silencer / exhaust pipe : option

8x4 HEAVY-DUTY FORWARD CONTROL TRUCK

CYH

GVM 41,000kg



BODY APPLICATIONS

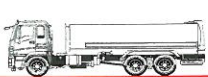

Tanker



Insulated Van



Dumper



Concrete Mixer



Concrete Mixer



Concrete Pump

EXTERIOR COLORS



ARC WHITE



MARINE BLUE (OPTION)



GOLDEN YELLOW (OPTION)

4x2 HEAVY-DUTY FORWARD CONTROL TRACTOR UNIT

EXR

Tractor GVM 20,000kg
GCM 42,000kg / 45,000kg



Coupler (5th wheel) : option

6x4 HEAVY-DUTY FORWARD CONTROL TRACTOR UNIT

EXZ

Tractor GVM 33,000kg
GCM 60,000kg



Coupler (5th wheel) : option

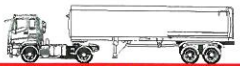

Tank



Low Bed



Drop Bed



Bulk Carrier



Flat Bed